

# Fitting & Pairing Guide

## Roman Blind

*Made For Your Windows,  
Powered For Your Convenience.*

*The Installation Of This Product Should Be Conducted By Someone Competent In DIY.*

### Fitting & Pairing Guide

In The Box	1
Installing Your Blind	2-3
Get To Know Your Remote	4
Pairing A Blind To A Remote	5-6
Advanced Settings	7
Safety Message	8-9



# In The Box

**NOTE**  
Do not free the blind with a knife or any object that may cause damage to the fabric.

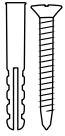

Screws  
Rawl Plugs



Wood  
Screws



Fixing brackets:  
quantity to suit  
length of blind

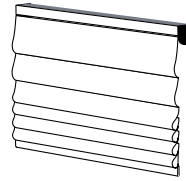

Blind



# Your Controls

Your order includes the remote selected at checkout. Additional controls are available at [www.poweredblinds.co.uk](http://www.poweredblinds.co.uk)

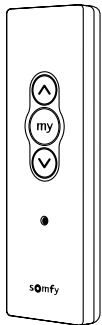

**SITUO RTS**  
Single Channel Control

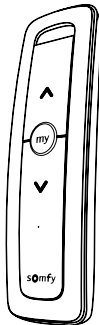

**SITUO 1 RTS PURE**  
Single Channel Control

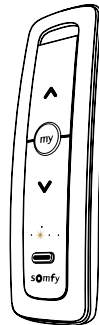

**SITUO 5 RTS PURE**  
Multi Channel Control



**TELIS 6 CHRONIS PURE**  
Six Channel Control

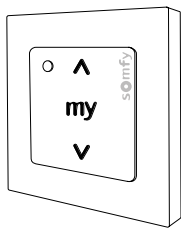

**SMOOVE ORIGIN RTS**  
Single Channel Control

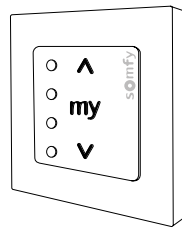

**SMOOVE ORIGIN 4 RTS**  
Four Channel Control

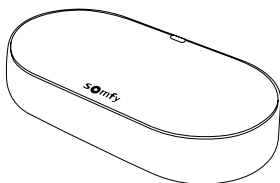

**Hub**  
Connectivity Kit

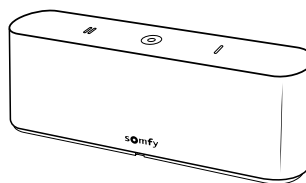

**Hub**  
TaHoma Switch



## Fitting Hardware

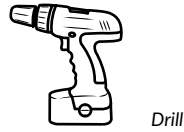
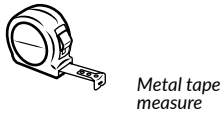

1

### Positioning The Brackets

Decide how you'd like to mount your brackets. Choose the method that best suits your window and space.

#### Deciding Where To Mount The Brackets

We have sent you universal brackets which allow top fixing and face fixing. When positioning the brackets allow room for the blind to clear any obstacles such as door or window handles when deployed.

**Fix brackets approximately 40mm from each end of the blind. Intermediate brackets should then be spaced evenly between these.**

**The headrail shall not be installed at less than 1.5 m from the floor.**

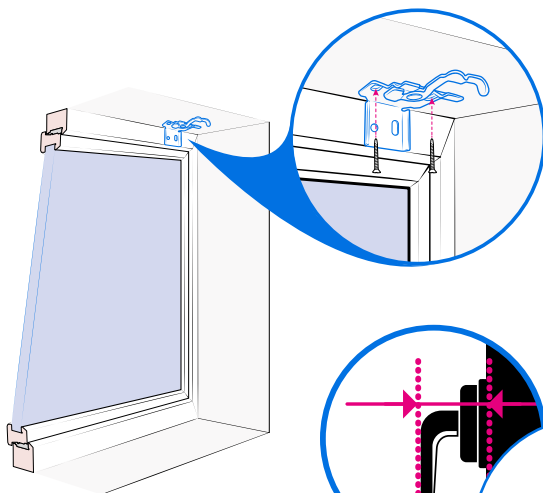
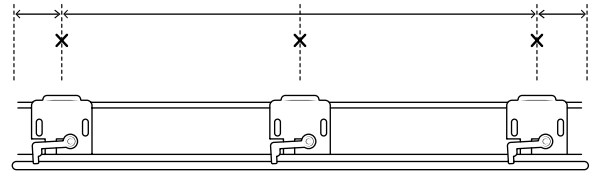

Top Fix

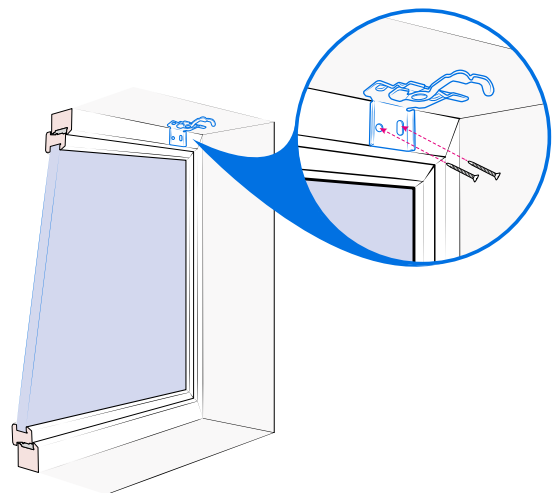

Face Fix

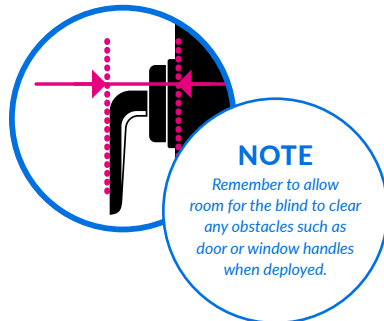

## Fitting The Headrail To The Brackets

Push swing arm anti-clockwise as far as it will go. Now clip the blind over the bracket. First easing the front lip of the headrail into place. Push swing arm clockwise until it locks into place, firmly holding the blind headrail.

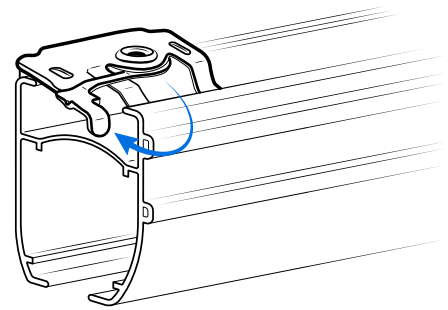
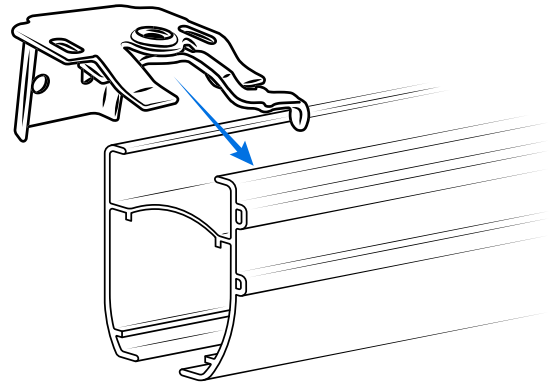



**Channels**

A remote can have one or more channels depending on your purchase. You can pair up to ten blinds per channel which will all be operated at the same time.

*Note: Other Somfy controls and wall switches will operate the same way based on the control buttons.*

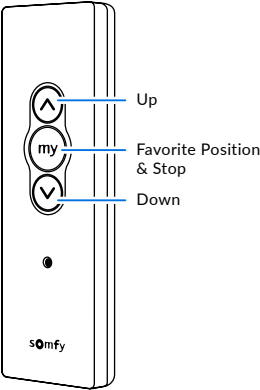

**SITUO RTS**  
Single Channel Control

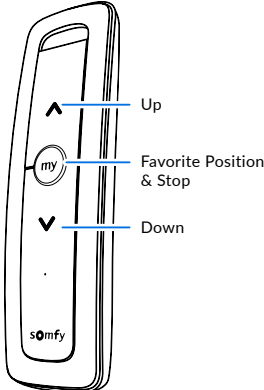

**SITUO 1 RTS PURE**  
Single Channel Control

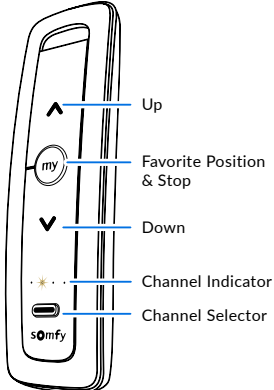

**SITUO 5 RTS PURE**  
Multi Channel Control

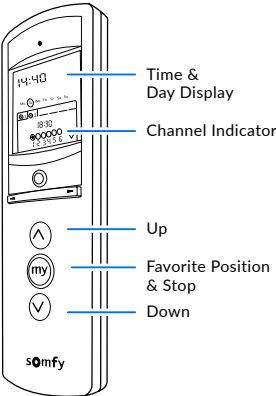

**TELIS 6 CHRONIS PURE**  
Six Channel Control

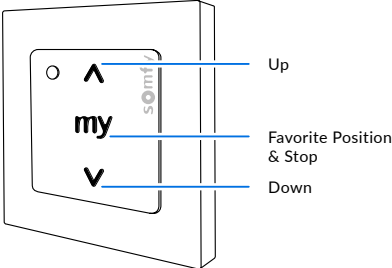

**SMOOVE ORIGIN RTS**  
Single Channel Control

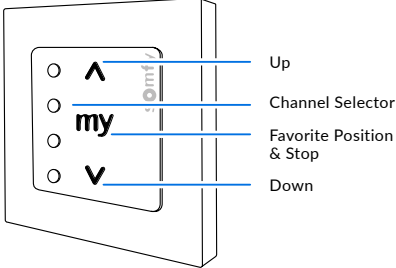

**SMOOVE ORIGIN 4 RTS**  
Four Channel Control



## Before You Begin The Pairing Process Activate Your Motor

To activate the motor, connect the battery to the motor. The blind will jog up and down three times indicating the motor is active. The blind is now ready to pair with the remote.

If your blind doesn't jog, simply plug in the power adapter for 3-4 hours.

**Note:** the charging connector will only fit one way. See graphic for more information.

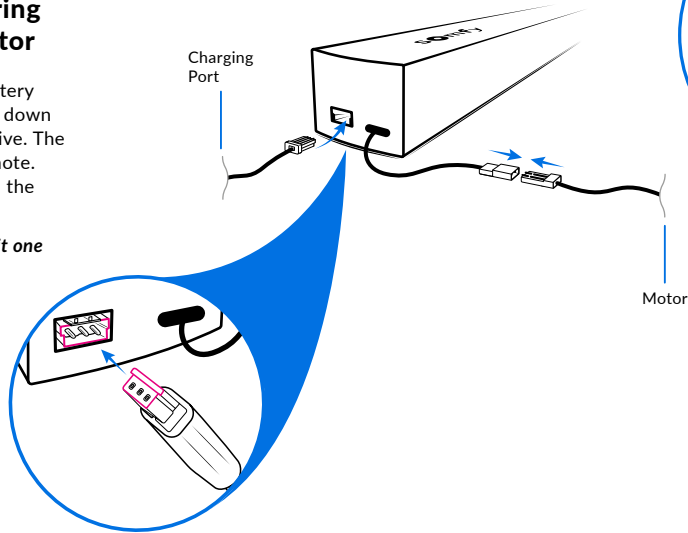

### NOTE

If you are setting up multiple electric blinds, complete the setting up process of one blind before waking up any subsequent blinds.

1

## Pairing A Blind To A Remote

Whether you're setting up a single channel remote, or a multi channel remote, the setting up process is exactly the same.

- 1 If you are using a multiple channel remote, set your remote to the channel you will connect this blind to.
- 2 To pair your remote to the blind, press the **UP** and **DOWN** BUTTONS on your remote together.

The blind will then briefly jog up and down indicating it is now paired with the remote.

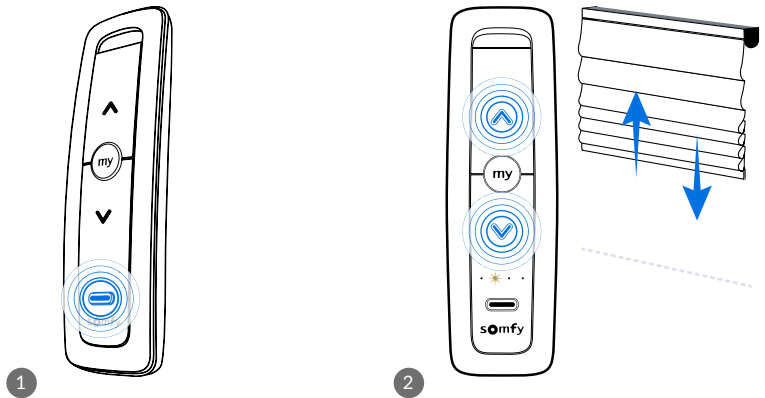

2

## Checking The Direction Of Travel

- 1 Check the direction of travel by pressing and holding the **DOWN** BUTTON until the blind moves. Release the button to stop it. If the blind moves downwards, it is correctly set up and you can progress directly to **step 3**.
- 2 However, if the blind starts to go up while pressing the down button, press and hold the **"MY"** button until it jogs, and press the **DOWN** BUTTON again to lower your blind and verify the direction is now set correctly.

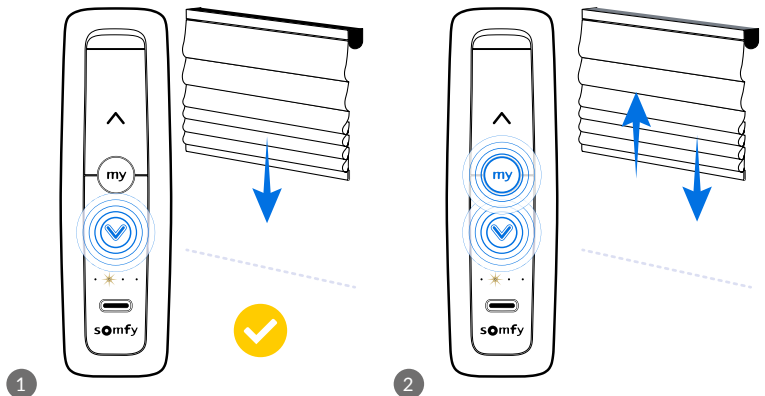

## Setting Your Blind's Open & Closed Positions

- 1 To set the closed position for your blind, press and hold the DOWN BUTTON to move your blind and once at the desired location release the button. You can fine tune this by tapping the up and down buttons as required.
- 2 Once the blind is in your preferred closed position, press and hold both the "MY" BUTTON and the UP BUTTON simultaneously. When the blind begins to rise, the closed position has been set.
- 3 Press the "MY" BUTTON when your product reaches the desired open position. You can fine tune this position by tapping the up and down buttons as required.
- 4 Once the blind is in your preferred open position, press and hold both the "MY" BUTTON and the DOWN BUTTON simultaneously. When the blind begins to lower, the open position has been set. The blind will automatically stop at your preferred closed position.

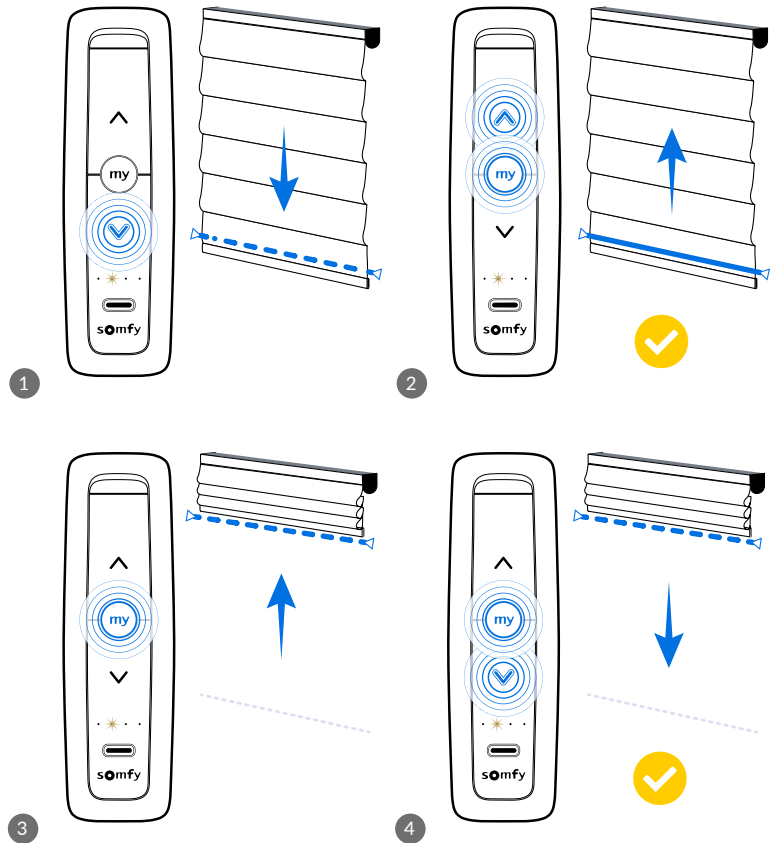

## Completing The Pairing Process

- 1 Press and hold the "MY" BUTTON until the blind briefly jogs up and down.
- 2 Complete the process, using a pin or paperclip to tap (0.5s) the "PROG" BUTTON on the back of the remote once. The blind will jog up and down to confirm. The programming process is complete and the blind motor is programmed.

*The blind will now operate with a brief press of the Up or Down buttons and automatically stop at the preset stop positions.*

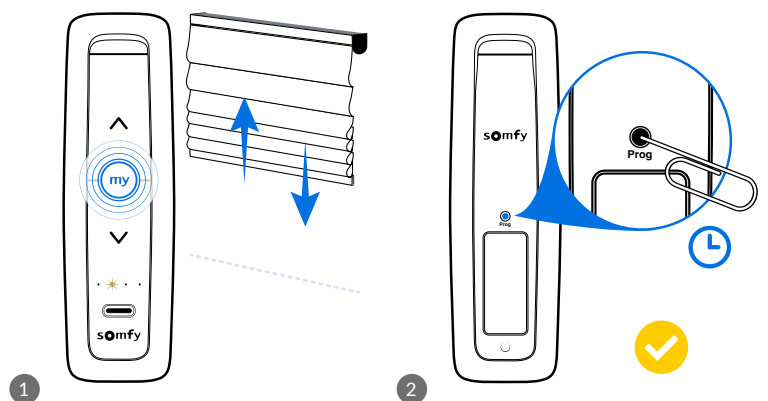

## Before Setting Up Your Next Blind

Before moving to the next blind, activate sleep mode for the previously set up blind(s) by disconnecting their batteries.

Do not plug any batteries back in until all blind limits have been set.

**Once all blinds are set up, reconnect the batteries to each blind.**

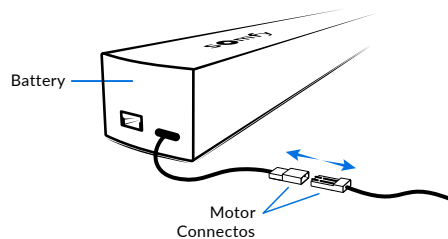

### NOTE

You must have completed the previous steps including the completing the programming process before moving on to set up the next blind.



## Recharging The Battery

Depending on the size of your blinds, the motor will need recharging typically every 6-12 months. Your motor contains a built-in rechargeable battery, and when the battery needs recharging, the blind will jog intermittently to draw attention. To charge the batteries, simply plug in the provided power adapter for 3-4 hours. It will jog and the LED on the plug will turn red. Once the LED turns green, the battery is fully charged.

**Note: the charging connector will only fit one way. See graphic for more information.**

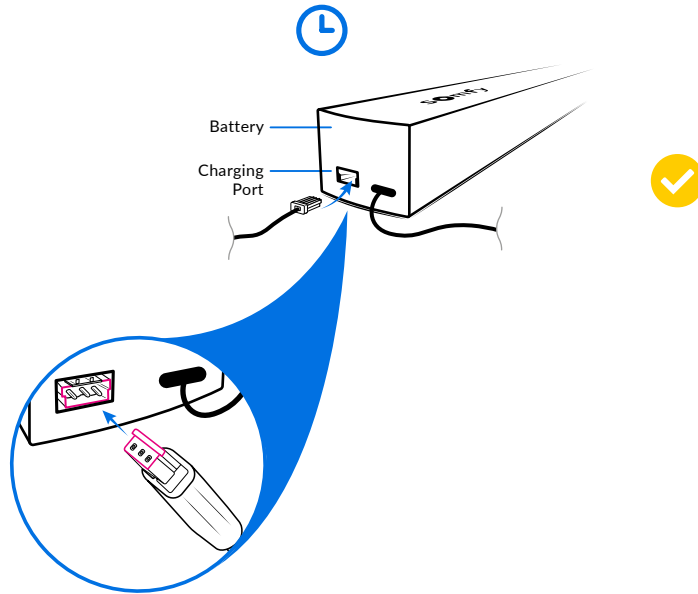

## Advanced Settings

### Adding Multiple Blinds To A Control Channel On A Multichannel Remote

- To add multiple blinds to one channel so that they operate at the same time, follow these steps.
- Select the existing channel you'd like to copy then press and hold the "prog" button on the back of the remote until the blind jogs.
- Select the channel to become the "multi blind channel" and tap the "prog" button on the back of the remote until the appropriate blind jogs. This indicates the settings have been copied.
- Repeat as needed to add more blinds to your designated "multi blind channel".

### Setting A Favourite Position

- Using the up and down buttons as required, find a position that you'd like to favourite and press the "MY" button to stop the blind.
- Press and hold the "MY" button until the blind briefly jogs up and down. The position is now set.
- Once set, simply press the "MY" button to move the blind to your favourite position.

### Adjusting Upper & Lower Limits

- Once your blind is set up, if you need to edit your open or closed limits, first move your blind to the limit you want to adjust.
- Click and hold the up and down buttons simultaneously until the blind jogs up and down.
- Click and hold the up or down buttons to move the limit.
- Click and hold the "MY" button until the blind jogs to confirm the new limit.

### Changing Speed

- To change the speed of your blind, first move the blind to a non-preset position.
- Press all three buttons on the front of the remote at the same time.
- The blind will begin moving up and down to demonstrate the speed options.
- Click and hold the up button, the blind will stop, jog and move to a quicker setting.
- Alternatively, hold the down button, the blind will stop, jog, and move to a slower setting.
- If the blind has reached the quickest or slowest setting, the blind will jog up and down three times and continue moving. Click and hold the "MY" button to confirm the new speed. The blind will jog to confirm.



### Electric Blinds - Recycling Expired Batteries

We are committed to reducing waste. As part of this commitment we will accept returned batteries and arrange for the recycling of expired batteries from your electric blind.

#### To arrange collection:

- Call 01484 622555 - and let us know you are planning to return your battery.
- Remove the motor housing the battery from the blind and package securely, including your original order number on the packaging.
- Arrange delivery of your package via a courier of your choice.
- Upon receipt the battery will be recycled with appropriate waste management services.



## WARNING

Reduce risk of strangulation to infants and toddlers. Position safety cord-stops before using blinds

The cord length on all blinds will be as follows: If the full drop of your blind is less than 2.5 metres, the cord will be 1 metre long. If the full drop of your blind is over 2.5 metres, the cord will be 2/3 the length of the blind.

If you require a longer cord than is standard, please call us to discuss, before ordering. Please be aware that we will need the installation height of your blind (from the top of the fitting location, down to the floor). There are still restrictions on the length of the cord.

- 1 Breakaway consolidators are provided on all blinds. The consolidator will come pre-attached to your blind. If any weight is placed on the cords the breakaway consolidator will break apart. In the event of this, check that it is not damaged, re-insert the free cords and click the sections back together.
- 2 Child Safety Device (Safety Cleat) The device should be installed as close to the headrail as possible. Each section of the safety device must be at least 10cm apart.  
Use double sided tape, or similar, to stick the tensioning device to the wall temporarily while preparing to drill and screw permanently into place.  
Always wrap all loose cords around the cleat in a figure of 8 pattern.

The assembly and installation of this product can be completed by non-professionals, in accordance with current trade and safety standards. Please consult a professional if any doubt exists. The headrail shall not be installed at less than 1.5 m from the floor.

Young children can be strangled by loops in pull cords, chains, tapes, and inner cords that operate the product.

- To avoid strangulation and entanglement, keep cords out of the reach of young children.
- Cords may become wrapped around a child's neck.
- Move beds, cots and furniture away from window covering cords. Do not tie cords together.
- Make sure cords do not twist and create a loop.

The assembly and installation of this product can be completed by non-professionals, in accordance with current trade and safety standards. Please consult a professional if any doubt exists.

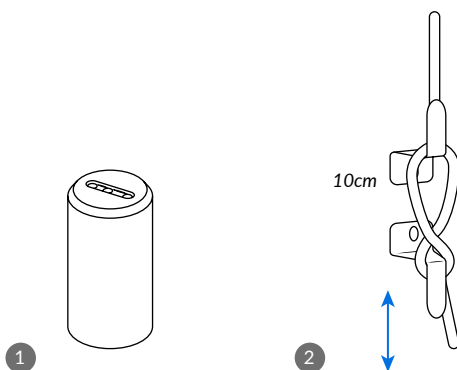
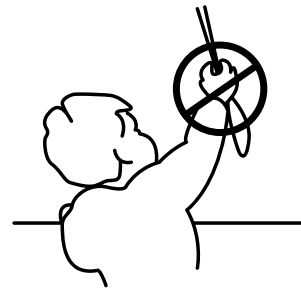



## Further Safety Information

---

### **Please read and follow all safety instructions carefully before installation and use.**

- **Children's Safety:** Never allow children to play with the blind or its control device. Keep remote controls and switches out of reach of children at all times.
- **Safe Installation:** Ensure the product is installed securely following these fitting instructions. The control switch (if used) must be positioned within sight of the blind's movement but away from moving parts and at a height compliant with national safety regulations (ideally below 1.3m where possible).
- **Do Not Modify:** Do not alter the product's design, wiring, or configuration without consulting the manufacturer or authorised representative. Modifications may compromise safety and invalidate your warranty.
- **Manual Release (where applicable):** Take care when operating any manual release feature, particularly if the blind or curtain is raised, as it may lower rapidly.
- **Inspection & Maintenance:** Regularly check the blind, power cables, and controls for signs of wear or damage. If damage is found, stop using the product and contact your retailer or installer for advice.
- **Electrical Safety:** Always disconnect the product from the power supply before carrying out cleaning, maintenance, or inspection of electrical parts.
- **Operating Out of View:** If operating your blind or curtain remotely without a direct line of sight, ensure no one is in the area during movement - particularly during cleaning or maintenance near windows or walls.
- **Noise Levels:** The noise emission level of this powered blind or curtain track is  $\leq 70$  dB(A), which is below the level considered hazardous to hearing.
- **Retain for Reference:** Keep these instructions for future reference and share them with anyone who may operate or maintain the pro.